

ANALYSIS OF ELEMENTS OF THE MELT AREA FOR LASER WELDING

Ramona Laslău¹ Remus Boboescu²

¹ University Politehnica Timisoara Romania ramonalaslau@yahoo.com

² University Politehnica Timisoara Romania remus_boboescu@yahoo.com

ABSTRACT: Laser welding using Nd: YAG laser with continuous emission is applied for low alloyed steel. The study pursued molten areas characteristics in the material. On the weld cross section was measured weld width, weld depth and the weld molten zone. Their variation was analyzed with power and welding speed. A full factorial experimental design was applied for two particular values of the distance between focal plane and the workpiece surface (defocusing depth). It presents mathematical models, the ranking effects by Pareto charts, response surface method and the multiple ANOVA analysis of variance. It showed the main effect of laser power in determining the weld characteristics.

KEY WORDS: laser welding, Nd:YAG laser, full factorial design, laser beam defocusing, mathematical model

1. INTRODUCTION

Laser welding is widely applied machining of metals and in particular for steels. The laser beam is a concentrated heat source that allows for the intensity of the laser beam 10^4 - 10^7 W/cm² and for interaction time between laser radiation and the material 10^{-3} - 10^{-2} s obtaining molten zones. Melting material is used for welding. Several papers have presented the features of the steel melted zone for laser welding [1]. Main information about the weld characteristics are given by the weld cross section. On this are measured the weld width, weld depth and the weld molten zone area. Sectioning the welds in a stable area provides information about the ability to perform laser beam melting material. Applied the mathematical modeling for the molten zone of welds is useful for estimating the parameter values used in making welded joints. Type the full factorial experiment with the statistical method of ANOVA analysis of the multiple underlying several methods of statistical analysis in experimental research [2] [3].

The problems addressed in this paper are close to that addressed in subsequent studies. Thus the varied parameters considered, laser power, welding speed and defocusing were applied in studies [4], [5] and [6]. Particular interest for variations caused by defocus on welding characteristics was presented in the works [7], [8], [9]. In these studies the laser beam was focus within the piece. Focusing the laser beam over the piece was used in the work [10]. As measured sizes characteristics showing the weld width and weld depth are of main importance [11] [12]. Melted area on weld cross-section was presented in the paper [13]. Studies using factorial type experimental plans were presented in [14].

Experiments performed by factorial experimental plans allow for the objective function variation as a function of three or two variables representing influence factors. This variation leads to formulas of correlation between the value of objective function values and factors of influence called "mathematical model" or "empirical model". This function type is preset as a polynomial in the variable values that appear influence factors and multiplications of them named interactions between factors. Choosing this type of model is related to the question about influence factors hierarchy. This is to determine that which of the influence factors or their interactions have the greatest contribution for objective function value. Contributions of

effects are analyzed by ANOVA method for variations analysis.

The mathematical model, written in coded system, presents important information on variations:

-Hierarchy of influence factors is due by the regression coefficient by comparison of their modules.

-Type of variation for objective function (upward or downward) with effect is given by the sign of regression coefficient.

At this information is added the correlation from ANOVA tables coefficients that give validity to the experimental model.

Pareto chart showing the hierarchy of factors influence the statistical significance of model. Response surface shows graphic (three dimensional) objective function variation with two of influence factors. Pareto charts and response surfaces are auxiliary study methods that show the experimental results in a more accessible form. Mathematical modeling by factorial experiment was presented in [15]

This paper proposes a study on the laser welds made on the low alloy steel plates. Apply a complete factorial experimental design type 2² for two different experimental situations given by the focal plane position relative to the workpiece surface (Defocusing) for welds made using laser irradiation Nd:YAG under continuous regime. In experiments were varied laser power and welding speed.

2. EXPERIMENTS

The experiment consisted in made lines of fusion (welds), 110mm long, on Dillimax 500 steel plates with thickness of 10 mm (carbon steel, carbon content ≤ 0.16 %), figure 1. Was used a Nd: YAG Triumph Haas 3006D laser source with 3kW maximum power on a continuous wave regime CW. Laser beam was transmitted through a optical fiber with core diameter of 0.6 mm. The focus system made a focal spot with 0.6 mm diameter. Lens focal length was 200 mm. As protective gas argon was used with a flow rate of 20 l / min. Were used sheets of material with dimensions of 100×130×10 mm for which were made between 5 and 8 welds, with a distance of over 10 mm between welds. In experiments was varied the laser power, welding speed and distance between focal plane and piece surface (defocusing or

defocusing depth) figure 2. Welds were cut in the stable part of the weld near the place where welding process was stopped. Weld section was processed metallographic. Weld width, near the piece surface, and weld depth were examined using a microscope with precision of 0.01 mm. Melted area was measured directly by its footprint. Parameters varied in the experiments are presentations in Figure 2. To focus within the piece defocusing values are considered negative.

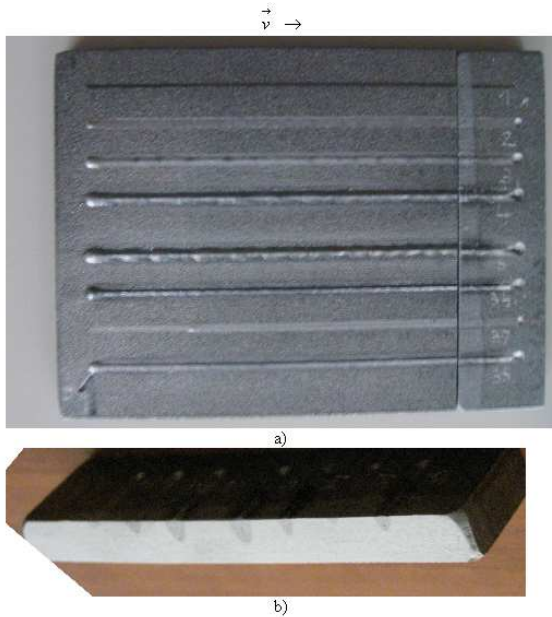

Figure 1. Plate with welds a) Surface plate b) cross- sections through the plate

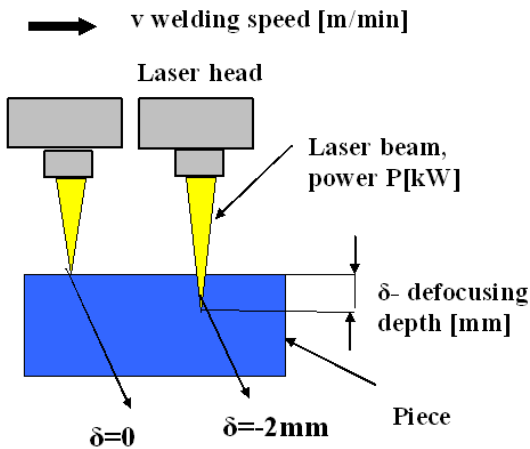

Figure 2. Varied parameters

In the experiments were varied power and welding speed. To statistically analyze the effects of parameters was necessary to introduce a dimensionless parameter values. Transformations between the two systems are based on real-coded relationships following:

$$A = P - 2 \quad (1)$$

$$B = -2.33 + 2.22v \quad (2)$$

The experimental plan is presented in Table 1 with actual values that coded for laser power and welding speed.

Analysis procedure consisted of presenting the results of the mathematical model, ANOVA table showing the correlation coefficients associated with the mathematical model, Pareto chart showing the hierarchy of effects and response surface is a graphic representation of mathematical model. For the mathematical model were presented two forms for real values

laser power and welding speed and for coded system values. The first allows rapid application of formulas and the second allows direct analysis of the values of regression coefficients. Based on these values were achieved Pareto charts.

Table1. Varied parameters in the experiment

weld	power		speed		defocusing
	A[-]	P[kW]	B[-]	v[m/min]	δ [mm]
1	-1	1	-1	0.6	0
2	+1	3	-1	0.6	
3	-1	1	+1	1.5	
4	+1	3	+1	1.5	
5	-1	1	-1	0.6	-2
6	+1	3	-1	0.6	
7	-1	1	+1	1.5	
8	+1	3	+1	1.5	-1
9	0	2	0	1	
10	0	2	0	1	

On the weld cross section was measured near the surface of the weld the width w [mm], at the center of the weld the depth h [mm] and melted area MA [mm²]. These measurements are shown in Figure 3.

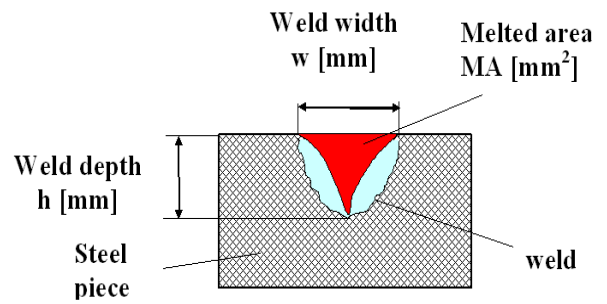

Figure 3. Weld cross-section with the considered sizes

3. WELD WIDTH

For the weld width at defocusing $\delta = 0$ polynomial mathematic model for is given by relations (3) (4). Statistical analysis of variation is given in Table 2.

$$w = 0.5018 + 0.55P - 1.221 v \quad (3)$$

$$w = 2.8833 + 0.55A - 0.55B \quad (4)$$

Table 2 ANOVA table for weld width w at $\delta = 0$

Effect	Sum of Squares	DF	Mean. Sq.	F-Ratio	P-val
A(power)	1.21	1	1.21	128.12	0.00
B(speed)	1.21	1	1.21	128.12	0.00
Total error	0.028	3	0.009		
Total (corr.)	2.448	5			
$R^2 = 0.988$		$R^2(\text{adj. for d.f.}) = 0.980$			

Pareto chart in Figure 4 shows that for focus laser beam at workpiece surface the weld width decreases with power and increases with welding speed. Effects of power and welding speed are equal and opposite sign. Both effects are statistically significant. The high effect of welding speed shows the importance of interaction time between laser radiation and material to obtain melt at the workpiece surface. The high intensity associated with laser beam focus at the workpiece surface results in the melt production of the workpiece surface even small interaction time between laser radiation and material.

Response surface in Figure 5 shows the variation weld width on the experimental field. Maximum weld width is obtained at maximum power and minimum welding speed.

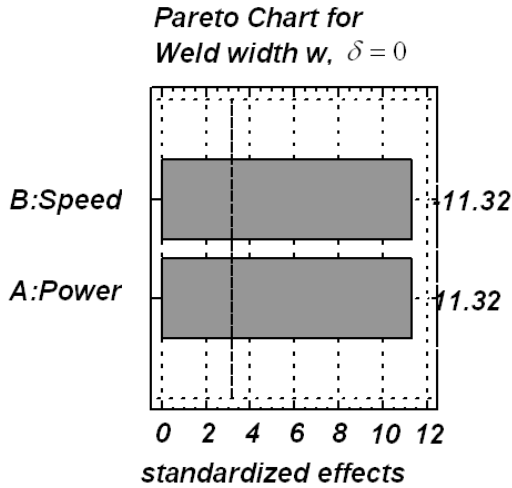

Figure 4. Pareto Chart for weld width at $\delta = 0$

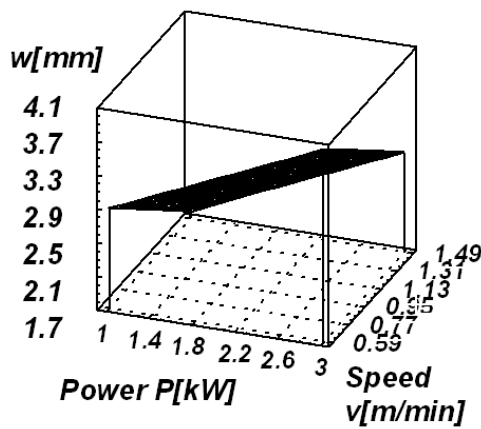

Figure 5. Response surface for weld width at $\delta = 0$

From the technological point of view are recommended values around the central point of the experimental field. Decrease the excess width is associated with reduced weld weld depth.

For the weld width at defocusing $\delta = -2mm$ mathematic model is given by polynomial equations (5) (6). Statistical analysis of variation is given in Table 3.

$$w = 1.9806 + 1.3P - 1.776v \quad (5)$$

$$w = 2.7166 + 1.3A - 0.8B \quad (6)$$

Table 3 ANOVA table for weld width w at $\delta = -2mm$

Effect	Sum of Squares	DF	Mean. Sq.	F-Ratio	P-val
A(power)	6.76	1	6.76	38.38	0.00
B(speed)	2.56	1	2.56	14.54	0.03
Total error	0.528	3	0.176		
Total (corr.)	9.848	5			
$R^2 = 0.94$		$R^2 (adj. for d. f.) = 0.91$			

Pareto chart in Figure 6 shows that for the focus inside piece weld width increases with power and decreases with welding speed. Effect of power in this case is much higher than the welding speed. The effects of both parameters were statistically significant. It looks like that under lower intensity of laser beam on the piece surface of the power effect becomes more important.

Response surface in Figure 7 shows that on the experimental weld width increases with power. Variations with welding speed are much smaller than for that to the laser beam focus on the workpiece surface.

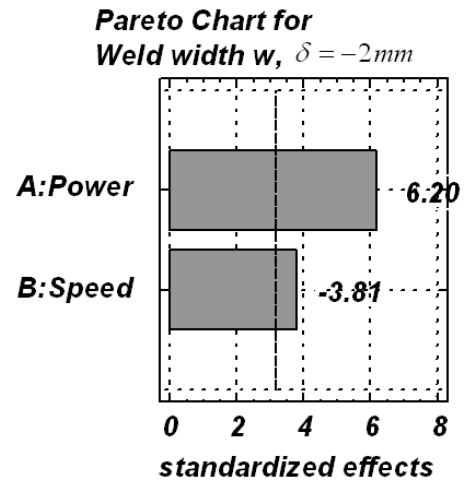

Figure 6. Pareto Chart for weld width at $\delta = -2mm$

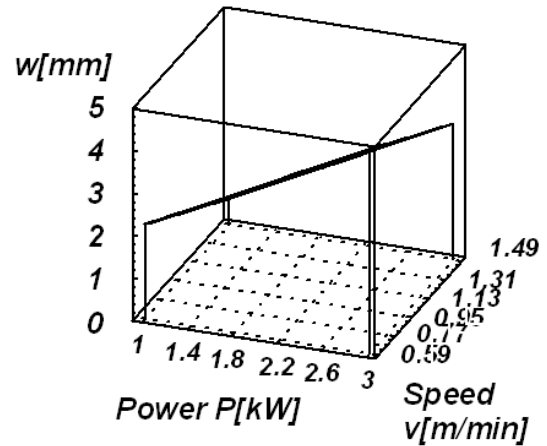

Figure 7. Response surface for weld width at $\delta = -2mm$

4. WELD DEPTH

For the weld depth at defocusing $\delta = 0$ polynomial mathematical model is given by equations (7) (8). Statistical analysis of variation is given in Table 4.

$$h = -1.694775 + 1.9675P - 0.72705v \quad (7)$$

$$h = 3 + 1.96A - 0.32B \quad (8)$$

Table 4. ANOVA table for weld depth h at $\delta = 0$

Effect	Sum of Squares	DF	Mean. Sq.	F-Ratio	P-val
A(power)	15.484	1	15.484	1564.94	0.00
B(speed)	0.429	1	0.429	43.36	0.00
Total error	0.029	3	0.009		
Total (corr.)	15.942	5			
$R^2 = 0.998$		$R^2 (adj. for d. f.) = 0.996$			

Figure 8 shows the Pareto chart for the weld depth for focus of laser beam at the workpiece surface. It is noted that the weld depth greatly increase with power and decreases with welding speed. Both effects have shown statistically significant. Effect of power is much greater than the welding speed effect. It looks like that the main role in determining the weld depth of is for laser beam intensity at the workpiece surface.

Response surface in Figure 9 shows that on the experimental weld depth increases with power, without significant variation for welding speed. Getting a high depth of the weld is associated with obtaining Keyhole welding regime

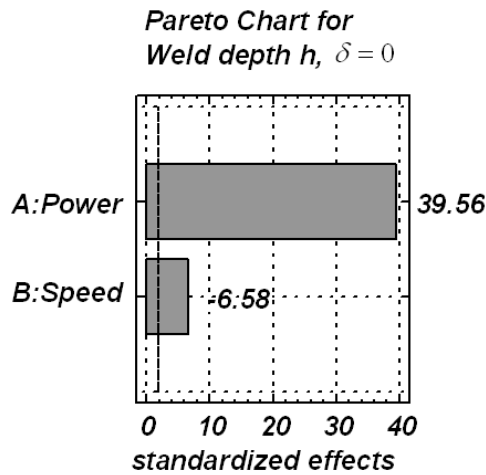

Figure 8. Pareto Chart for weld depth at $\delta = 0$

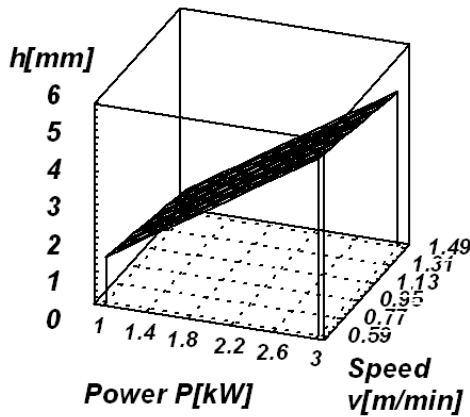

Figure 9. Response surface for weld depth at $\delta = 0$

For weld depth at defocusing $\delta = -2mm$ polynomial mathematical model is given by equations (9) (10). Statistical analysis of variation is given in Table 5.

$$h = -0.833 + 1.87P - 1.0656v \quad (9)$$

$$h = 2.538 + 1.87A - 0.48B \quad (10)$$

Table 5. ANOVA table for weld depth h at $\delta = -2mm$

Effect	Sum of Squares	DF	Mean Sq.	F-Ratio	P-val
A(power)	13.987	1	13.987	28.88	0.01
B(speed)	0.921	1	0.921	1.90	0.26
Total error	1.452	3	0.484		
Total (corr.)	16.362	5			
$R^2 = 0.91$		R^2 (adj. for d. f.) = 0.85			

Figure 10 shows the Pareto chart for the weld depth for the laser beam focus within the piece. In this situation the intensity of laser beam to the workpiece surface decreases.

Laser power increases the weld depth and welding speed decreases the weld depth. The main effect is that of power. This is statistically significant. It is noted that the difference between the effects of welding speed and power is much lower compared to the case where laser beam focusing is performed on the workpiece surface. It looks like that the effect of welding speed at low intensity of laser beam is much stronger.

Response surface in Figure 11 shows that on the experimental weld depth increases with power. There is a small decrease in the weld depth with welding speed. This type of variation shows that if maintaining a high level of power can be increased welding speed.

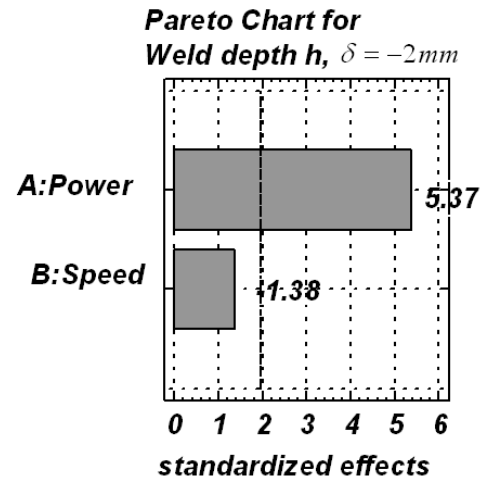

Figure 10. Pareto Chart for weld depth at $\delta = -2mm$

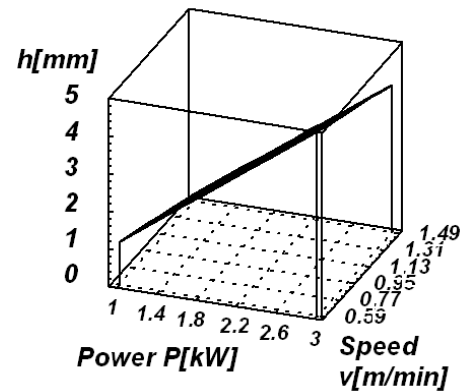

Figure 11. Response surface for weld depth at $\delta = -2mm$

5. MELTED AREA AT THE WELD CROSS SECTION

For melted area mathematic polynomial model at defocusing $\delta = 0$ is given by equations (11) (12). Statistical analysis is presented in Table 6.

$$MA = -5.4944 + 2.7P - 3.774v \quad (11)$$

$$MA = 3.8666 + 2.7A - 1.7B \quad (12)$$

Table 6. ANOVA table for melted area MA at $\delta = 0$

Effect	Sum of Squares	DF	Mean Sq.	f-Ratio	P-val
A(power)	25.180	1	25.180	16.45	0.03
B(speed)	11.560	1	11.560	7.55	0.04
Total error	4.61	3	1.53		
Total (corr.)	45.333	5			
$R^2 = 0.89$		R^2 (adj. for d. f.) = 0.83			

Figure 12 shows the Pareto chart for the melted area on the weld cross section for the laser beam focus to workpiece surface. It is noted that the melted area increases with power and decreases welding speed. Power effect is statistically significant. It is noted that the contribution of welding speed is higher than for the weld depth.

Response surface in Figure 13 shows that the maximum of melted area on the experimental field is obtained at high power and low welding speed. At low welding speed the power effect has much greater contribution. From the technological point of view is recommended for high value power and moderate values for welding speed.

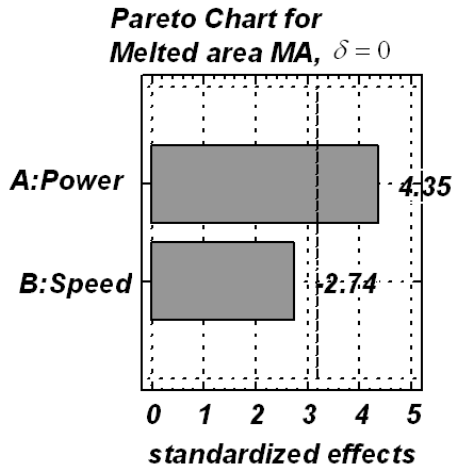

Figure 12. Pareto Chart for melted area at $\delta = 0$

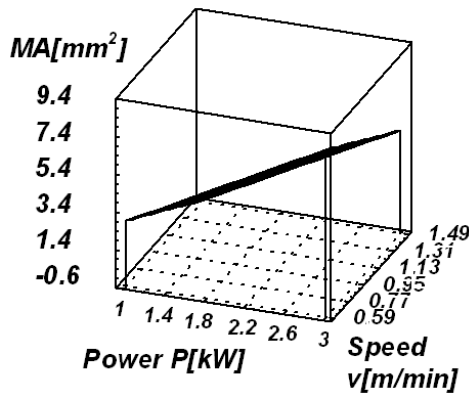

Figure 13. Response surface for weld melted area at $\delta = 0$

For melted area mathematic model polynomial at defocusing $\delta = -2mm$ is given by equations (13) (14). Statistical analysis is presented in Table 7.

$$MA = 1.8025 + 3.025P - 4.16250v \quad (13)$$

$$MA = 3.48 + 3.025A - 1.875B \quad (14)$$

Pareto diagram of Figure 14 presents the effects of power and welding speed on the molten area. It shows that the melted area increases with power and decreases with welding speed. The relative contribution of these two parameters is the same as for the laser beam focus at the workpiece surface. It looks that defocusing produces small fluctuations in the molten zone sizes.

Table 7. ANOVA table for melted area MA at $\delta = -2mm$

Effect	Sum of Squares	DF	Mean Sq.	f-Ratio	P-val
A(power)	36.602	1	36.602	6.51	0.08
B(speed)	14.062	1	14.062	2.50	0.21
Total error	16.863	3	5.621		
Total (corr.)	67.528	5			
$R^2 = 0.75$		$R^2(\text{adj. for d.f.}) = 0.58$			

Response surface in Figure 15 shows that maximum values are obtained for the fused area at maximum power and minimum welding speed. Melted area values are higher than that for the

case where the laser beam was focus on the workpiece surface. It looks like the laser beam focuses inside piece produces more efficient the melt.

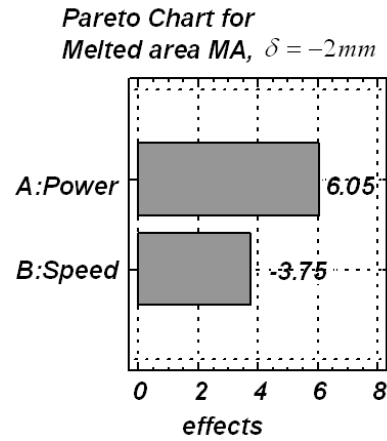

Figure 14. Pareto Chart for melted area at $\delta = -2mm$

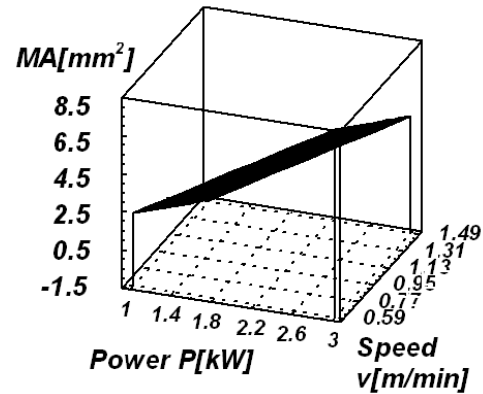

Figure 15. Response surface for weld melted area $\delta = -2mm$

6. CONCLUSIONS

Weld cross section showing the main aspects of the welding process. Its stated the following:

- The amount of melt produced in the material increases with power and decreases with welding speed.
- Laser power has the main effect on the characteristics of the weld.
- Focusing the laser beam inside piece increase the welding speed.
- Weld depth depends almost exclusively by the power and intensity of laser beam to the workpiece surface.
- Melted area is less influenced by the defocusing.

To achieve laser beam welding is recommended that welds have a depth close to the thickness of pieces and the melted zone area is maximal. Association was observed between the weld width and the weld depth. Wide welds had relatively high depth. Welds for that power value was fixed on the upper level were in keyhole regime and those who value power was fixed on the lower level were in the conduction welding regime. Focusing the laser beam inside the piece ($\delta = -2mm$) with the maximum power ($P = 3$ kW) produce welds in keyhole welding regime with a reduced number of pores.

7. REFERENCES

1. Kazuhiko Ono, Karoru Adachi, Yasuichi Matsumoto, Isamu Miyamoto, Takashi Inoue, Ryuichi Narita, Influence of oxide film on weld characteristic of mild steel in CO₂ laser welding, *Proceedings of the International*

- Conference, Applications of Lasers and Electro-Optics* (1999)
2. Benyounis, A.G. Olabi, M.S.J. Hashmi, Multi-response optimization of CO₂ laser-welding process of austenitic stainless steel, *Optics & Laser Technology* Vol.40 pp:76–87 (2008).
 3. Lung Kwang Pan, Che Chung Wang, Shien Long Wei , Hai Feng Sher, Optimizing multiple quality characteristics via Taguchi method-based Grey analysis, *Journal of Materials Processing Technology* Vol.182 pp:107–116 (2007).
 4. Abdel-Monem El-Batahgy Effect of laser welding parameters on fusion zone shape and solidification structure of austenitic stainless steels *Materials Letters* Vol.32 pp.155-163 (1997).
 5. Alexandra P. Costa, Luisa Quintino, Martin Greitmann Laser beam welding hard metals to steel, *Journal of Materials Processing Technology* Vol.141 pp.163–173 (2003)
 6. Tom Kugler and Mohammed Naeem, Material Processing With Super- Modulation Proceedings of the International Conference, *Applications of Lasers and Electro-Optics* (2002) .
 7. E. Akman, A. Demir, T. Canel, T. Sinmazcelik Laser welding of Ti6Al4V titanium alloys *Journal of materials processing technology* Vol.209 pp.3705–3713(2009)
 8. Cheolhee Kim, Junghak Kim, Hyunsik Lim, Jeonghan Kim, Investigation of laser remote welding using disc laser *Journal of materials processing technology* Vol.201 (2008) pp.521–525.
 9. Xiu-Bo Liu, Ming Pang, Zhen-Guo Zhang, Wei-Jian Ning, Cai-Yun Zheng, Gang Yu Characteristics of deep penetration laser welding of dissimilar metal Ni-based cast superalloy K418 and alloy steel 42CrMo, *Optics and Lasers in Engineering*, Vol. 45 pp.929–934 (2007)
 10. Rattana Borrisutthekul, Yukio Miyashita, Yoshiharu Mutoh Dissimilar material laser welding between magnesium alloy AZ31B and aluminum alloy A5052-O *Science and Technology of Advanced Materials* pp.1–6 (2005)
 11. Ulrich Durr, Ronald Holtz, Mathias Jokiel, Rene Liebers, Dave Lavoie Advanced micro-welding strategies with pulsed N:YAG lasers, *International Conference, Applications of Lasers and Electro-Optics* (2004)
 12. G. J. Shannon, J. Watson, W. F. Deans Laser welding in a high pressure gas environment Research note. *Optics & Laser Technology*, Vol. 27, No. 6, pp. 397-398. (1995)
 13. J. Greses, P.A. Hilton, C.Y. Barlow, W.M. Steen Plume Attenuation under High Power Nd:YAG Laser Welding *Proceedings of the International Conference, Applications of Lasers and Electro-Optics* 2002
 14. A. Ancona, T. Sibillano , L. Tricarico , R. Spina , P.M. Lugara,G. Basile, S. Schiavone Comparison of two different nozzles for laser beam welding of AA5083 aluminium alloy *Journal of Materials Processing Technology* (2005)
 15. Lung Kwang Pan, Che Chung Wang, Ying Ching Hsiao, Kye Chyn Ho *Optimization of N:YAG laser welding onto magnesium alloy via Taguchi analysis* *Optics & Laser Technology* Vol.37 pp.33 – 42 (2004)